

Rubberized Tack-on Tail Pulley Repair Kit

The Herren Brand Rubberized Tack-on Tail Pulley Repair Kit is eco-friendly. You can hold on to your worn out standard pulley, and rebuild to a heavy duty pulley. Our company is committed to manufacturing environmentally safe products for the sand and gravel industry.



Cut Your Tail Pulley Costs!

Rebuild your worn out standard pulleys to a heavy duty pulley at less than 1/2 the cost of a new one.

Rebuild your heavy duty pulleys and SAVE!

- **Heavy duty pulley at 1/2 the cost**
- **Lasts three times longer**
- **Replaceable lagging**
- **Strengthens the wings**

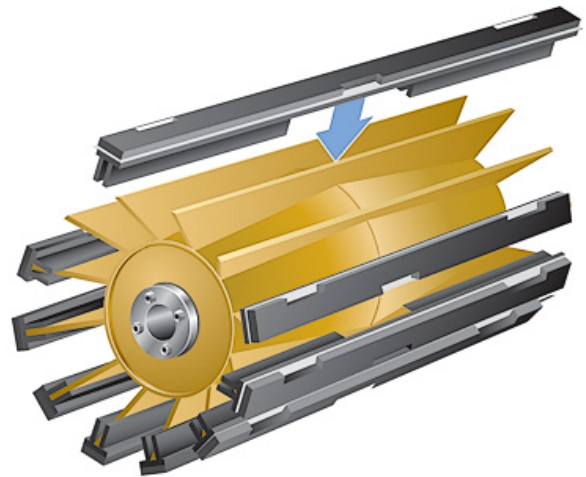

Replaceable Lagging Repair Kit

Replace the old worn out rubber wear strips with new lagging strips. Just grind off the old ones and tack weld the new rubber strips onto the wing.

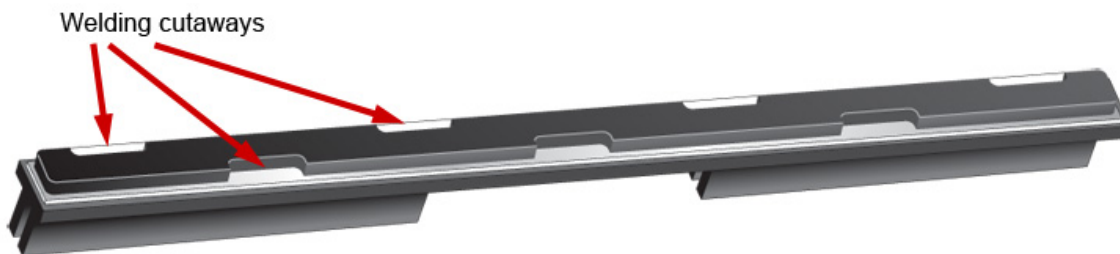

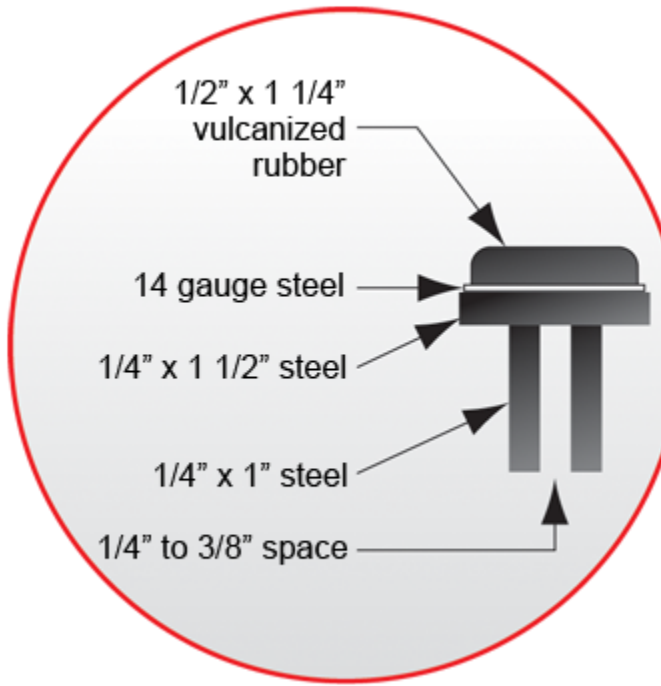

Replaceable Lagging Strip crosssection

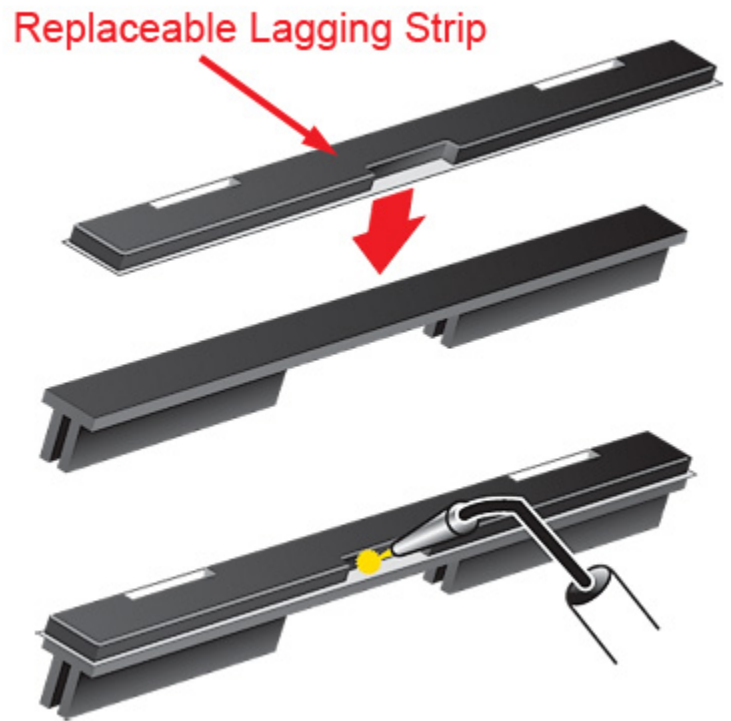

Ordering Instructions

When you order your Tack-on Rail Pulley Repair kit we will ask you for 2 measurements:

1. Length of wings
2. Number of wings